

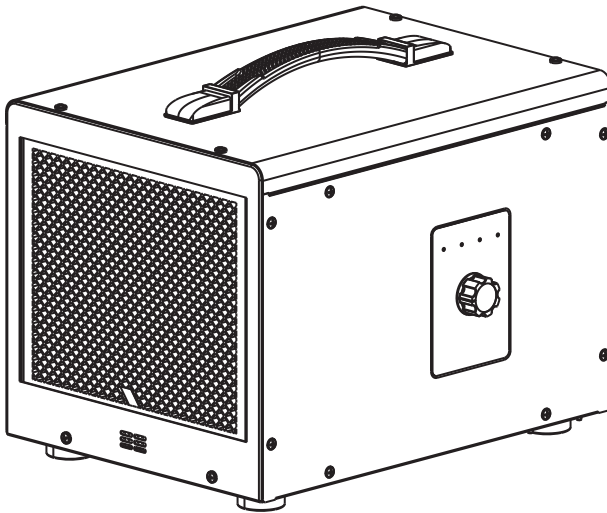

Sentinel HS35

Installation & Operations Manual



AlorAir Solutions INC.

Add: 14752 Yorba Ct Chino Ca91710 US

Tel: 1-888-990-7469

E-mail: sales@alorair.com



SAFETY WARNING

- Please read this user manual carefully before use.
- This machine uses an environmentally friendly refrigerant R32, with a filling capacity of 6.35 oz. The refrigerant is colorless, odorless and flammable, with combustion A2 level.
- Do not place the dehumidifier near flammable objects (for example: open flames, stoves, electric heaters).
- It is recommended to have a closed windows in the room where the dehumidifier will be placed. Opening the windows may be required in case of a refrigerant leak. When this issue occurs, contact our customer support.



WARRANTY REGISTRATION

Congratulations on purchasing a new Sentinel Dehumidifier. Your new dehumidifier comes with an extensive warranty plan. To register, simply fill out and return the warranty form provided in the dehumidifier box.

Be sure to note your dehumidifier serial number as you will need it for registration.

SAFETY NOTES

- The Sentinel Series Dehumidifier must always be connected using a grounded electrical connection (as required for all electrical appliances). If non-grounded wiring is used, all liability reverts to owner and the warranty is voided.
- Sentinel Dehumidifiers should only be maintained and repaired by a qualified technician.
- Sentinel Dehumidifiers are only intended for operation when oriented with the unit sitting on its feet and level. Operating the unit in any other orientation could allow water to flood electrical components.
- Always unplug dehumidifier before moving.
- If there is a chance that water flooded the dehumidifier, it should be opened and allowed to dry thoroughly before reconnecting to electrical power and restarting.
- To ensure proper operation, neither the inlet nor discharge should be positioned against a wall. The inlet requires a minimum of 6' clearance and the discharge requires a minimum of 6' clearance.
- For better use of the dehumidifier, both air inlet and air outlet should be facing the open area of the space.
- Do not insert your fingers or any object into the inlet or discharge.
- All work on the dehumidifier should be done with the unit "off" and unplugged.
- Do not use water to clean the exterior of the machine. To clean unit, unplug from power, then use a damp cloth to wipe exterior.
- Do not stand on the machine or use it as a device to hang clothes.
- **This appliance can be used by children aged from 8 years and above and persons with reduced physical, sensory or mental capabilities or lack of experience and knowledge if they have been given supervision or instruction concerning use of the appliance in a safe way and understand the hazards involved.**
- **Children shall not play with the appliance.**
- **Cleaning and user maintenance shall not be made by children without supervision.**

TABLE OF CONTENTS

Identification _____	1
Electrical Supply _____	1
Principle of Operation _____	1
Installation _____	2
Key Functions _____	2
Indicator Lights _____	3
Diagram _____	4
Maintenance _____	5
Dehumidifier Storage _____	5
Troubleshooting _____	6
Spare Parts _____	7
Warranty Information _____	8

IDENTIFICATION

For future reference, write down the model, serial number, and date of purchase for your dehumidifier. This is extremely helpful if you need to seek assistance in the future. The data label on the side of the device has the key characteristics of a particular machine.

Model: Sentinel HS35

Serial Number: _____ **Date of Purchase:** _____

For additional questions concerning your dehumidifier, the following options are available:

Contact your installing contractor

E-mail: sales@alorair.com

ELECTRICAL SUPPLY

Power Supply: 115 V, 60 Hz AC, Single Phase

Outlet Requirement: 3-prong, GFCI

Circuit Protector: 15 Amps

WARNING: 240 Volts AC may cause serious injury from electric shock.

To reduce the risk of injury:

1. Disconnect electrical power before servicing.
2. Only plug the unit into a grounded electrical circuit.
3. Do not use an extension cord.
4. Do not use a plug adapter.

PRINCIPLE OF OPERATION

The Sentinel Series Dehumidifier utilizes its integral humidistat to monitor the conditioned space. When the relative humidity goes above the selected set point, the dehumidifier will energize. Air is drawn across an evaporator coil, which is cooler than the dew point of air. This means moisture will condense out of the air. The air is then reheated through the condenser coil and distributed back into the room.

INSTALLATION

The area to be controlled should be sealed with a vapor barrier. If unit is installed in a crawlspace, all vents should be sealed.

WARNING: Do not install your dehumidifier in a corrosive environment. Some liquid vapor barriers dry via “solvent evaporation”. Always make sure that barrier is completely dry and area is thoroughly ventilated before installing dehumidifier.

Step #1: Place dehumidifier on a level surface.

Do not place directly on vapor barrier. For example, use blocks, or pavers to create a level surface. If the unit is handled in such a manner that the compressor did not remain in the upright position, you will need to place it on a level surface, then wait a minimum of 2 hours before turning "on".

Step #2: Set up drain line.

The transparent hose is directly placed on the interface of the drain port, the water pipe is inserted in place along the guide of the interface, and the installation of the water pipe is completed.

Step #3: Plug unit into 15 Amps grounded circuit.

KEY FUNCTIONS

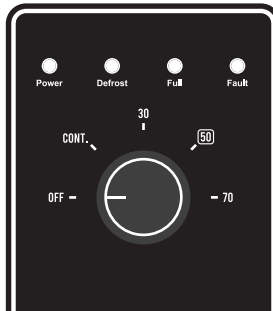

● OFF Gear

When the knob is in the OFF gear, turning it to any other gear will turn on the machine. When in any other gear, turning it back to the OFF gear will shut down the machine (the fan will delay shutting off for 2 minutes).

● CONT. Gear

This gear is for continuous running mode. The fan and compressor will start up, and the machine will run continuously without stopping automatically due to humidity changes.

- **30 Gear**

The humidity is set to 30%RH. When the humidity is below 30%RH the machine will automatically shut down.

- **50 Gear**

The humidity is set to 50%RH. When the humidity is below 50%RH the machine will automatically shut down.

- **70 Gear**

The humidity is set to 70%RH. When the humidity is below 70%RH the machine will automatically shut down.

- **Drainage system**

During operation, condensate water will be automatically drained by gravity. If you need to move the machine, please wait at least 10 minutes for it to fully defrost. Then tilt the machine slightly towards the “gravity drainage” side to drain the condensate water. Making sure it's completely drained, to prevent water from spilling out and damaging internal components during the moving process.

INDICATOR LIGHTS

- **Power Indicator**

The indicator will remain lit when the machine is turned on.

- **Defrost Indicator**

The indicator will light up when the machine is defrosted. Otherwise, it will remain off.

- **Full Indicator**

The indicator will light up when the reservoir is full.

- **Fault Indicator**

If the indicator blinks twice, is an “E1” error.

- when there is a humidity sensor malfunction or no data, it will be judged as a fault “E1” after 30 seconds.

If the indicator blinks three times, is an “E5” error.

- When the compressor is running, if the coil temperature \geq (ambient temperature -3 degrees) for 30 consecutive minutes, an “E5” error is detected, and the condensing agent is missing (except for defrosting). The machine stops and cannot be operated (it needs to be powered on again). After the machine is powered on again, the machine runs continuously for another 30 minutes to make a judgment.

SENTINEL HS35 DIAGRAM

Front View

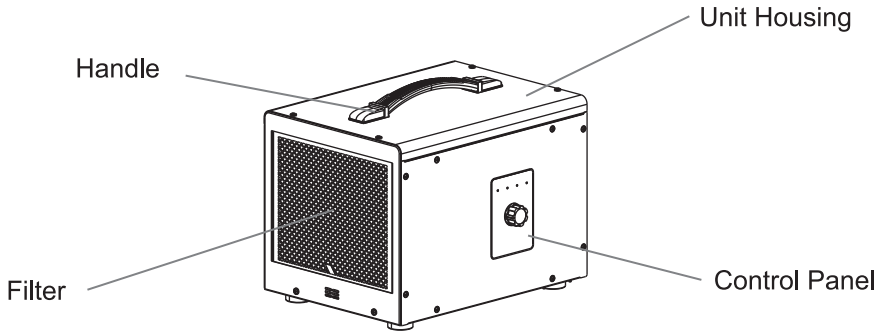

Rear View

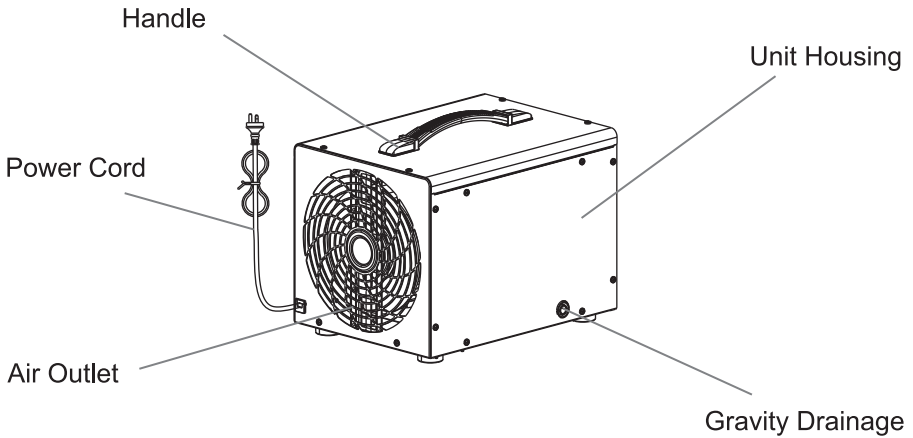

MAINTENANCE

WARNING: Always unplug the unit before doing any maintenance.

Cleaning the machine body

Use a soft damp cloth to clean exterior of unit. Do not use any soap or solvents.

Coil Maintenance

- Once per year, clean the coils with an approved coil cleaner.
- Coil cleaner should be a self rinsing, foaming cleaner such as WEB® Coil Cleaner.

DEHUMIDIFIER STORAGE

If the unit will be stored for an extended period of time, complete the following steps:

1. Turn off the unit and allow to dry.
2. Wrap and secure the power cord.
3. Cover the filter mesh.
4. Store in a clean, dry space.

TROUBLESHOOTING

Symptom	Cause	Solution
Machine Won't Run	Power Supply	Verify that there is power to the outlet and that the plug is properly installed in outlet.
	Room Temperature Over 105 °F or Below 33 °F	The unit is outside the operating temperature range. Modify the room conditions so the temperature is between 33°F-105°F and operation will commence. (The set humidity must be lower than the ambient humidity.)
Low Airflow	Air Filter is Clogged	Clean the filter mesh according to instructions listed in manual.
	Air Inlet or Outlet is Blocked.	Clear the blockage from inlet or outlet.
Loud Noise	Machine Is Not Level	Move the dehumidifier to flat, firm ground.
	Filter Mesh is Blocked	Clean the filter mesh according to instructions listed in manual.
Trouble Code: E1 The fault indicator blinks twice	E1=Humidity Sensor Issues	Check to ensure that wire is connected at both ends. If no issues are visible, the sensor may be faulty.
Trouble Code: E4 The full indicator light up	The reservoir is full	1. Check whether the reservoir is full. If it is full, drain it. 2. Check whether the float switch works. 3. Check whether the motherboard chip is damaged.
Trouble Code: E5 The fault indicator blinks three times	Refrigerant Leak	Contact Your Installer for Assistance.

When relying on gravity drainage, the dehumidifier should be placed on a plane with a certain height. Remove the rubber stopper from the dehumidifier outlet and insert the water pipe to collect it into a storage tank or discharge it from the room.

Note: The water pipe should not be higher than the dehumidifier, should be placed downward.

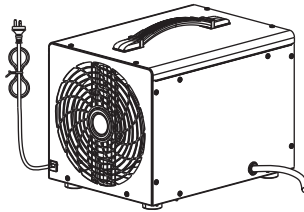

Troubleshooting when the "Full" indicator light up:

1. Drainpipes are blocked or wound and deformed by foreign objects.
2. The drainage height is exceeded, the water pipe should not be higher than the dehumidifier, and should be discharged downward.
3. Water level sensor malfunction.

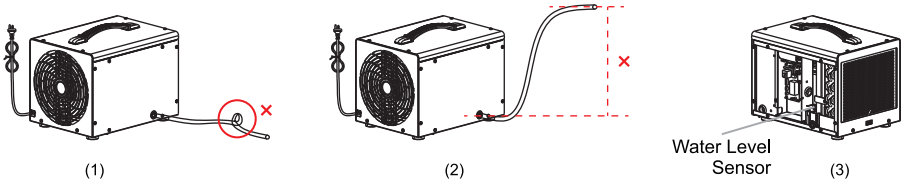

SENTINEL HS35 SPARE PARTS

Sentinel HS35 - Parts	
Part#	Description
S-110	RH/Temperature Sensor
S-601	Fan Motor
S-602	Complete Fan Assembly
S-603	Fan Capacitor
S-604	Compressor
S-605	Compressor Capacitor
S-606	Coil Assembly
S-607	RH/Temperature Sensor Cable
S-610	Foot,adjustable

Sentinel HS35 - Filters	
Part#	Description
S-612	MERV-1 Filter

LIMITED WARRANTY

This limited warranty starts from the date of purchase, AlorAir Solutions Inc. warrants to the original purchaser that this AlorAir product is free from manufacturing defects in material or workmanship for the limited warranty period of:

Six (6) Month parts and labor. This includes the shipment charges for replacement parts or unit.

One (1) year parts and labor. This does not include the shipment charge to send the defective product back to be repaired or replaced.

Three (3) years parts and labor on Refrigeration System ONLY (Compressor, Condenser, and evaporator). Transportation cost, not included.

Five (5) years parts on Refrigeration System ONLY (Compressor, Condenser, and evaporator). Transportation cost, not included.

This limited warranty is valid only on products purchased from the manufacturer or AlorAir authorized dealer and operated, installed, and maintained according to the instructions included in this user guide or furnished with the product. AlorAir Solutions Inc. will not provide in-home service during or after the warranty period. You may be responsible for the shipping charge to bring the product to the manufacturer for service.

To receive warranty service, the purchaser must contact AlorAir at [888-990-7469](tel:888-990-7469) or support@alorair.com. A proof of purchase or order number is required to receive warranty service. During the applicable warranty period, a product will be repaired or replaced at the sole option of AlorAir.

IMPORTANT NOTICE: Keep the item's packaging in case warranty service is required.

LIMITED WARRANTY EXCEPTED

This limited warranty covers manufacturing defects in materials or workmanship encountered in normal household, commercial or noncommercial use of this product and shall not cover the following:

- Damage occurs in uses for which this product was not intended for.
- Damage caused by unauthorized modification or alteration of the product.
- Cosmetic damage including scratches, dents, chips, and other damage to the product's finishes.
- Damage caused by abuse, misuse, pest infestation, accident, fire, floods, or other acts of nature.
- Damage caused by incorrect electrical line current, voltage, fluctuations, and surges.
- Damage caused by failure to perform proper maintenance of the product.

The use of this product in SPA or a room with OUTDOOR POOL invalidate or voids limited warranty.

CIRCUIT DIAGRAM

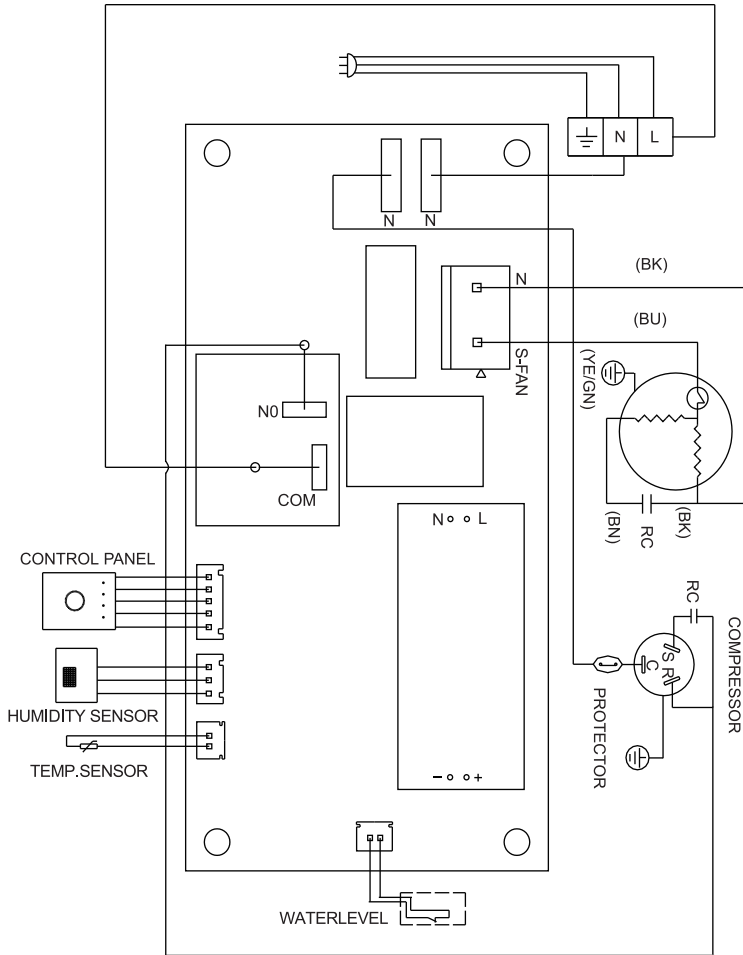



WARRANTY REGISTRATION CARD

ORDER NUMBER: _____

MODEL: _____ SERIAL #: _____

INSTALLER: _____ INSTALLATION DATE: _____

NAME: _____

ADDRESS: _____

CITY: _____ STATE: _____ ZIP: _____

PHONE #: _____ EMAIL: _____

Return To:
AlorAir Solutions

- ▶ If you have any questions, please feel free to contact us at [888-990-7469](tel:888-990-7469) or visit www.alorair.com
- ▶ Register your unit for warranty using this link: www.alorair.com/page/Warranty--Warranty-registration
- ▶ Warranty Registration <https://www.alorair.com> or scan this barcode to direct you to the warranty registration website.





Information on the disposal for Waste Electrical & Electronic Equipment (WEEE) This symbol on the products and accompanying documents means that used electrical and electronic products should not be mixed with general household waste. For proper disposal for treatment, recovery and recycling, please take these products to designated collection points where they will be accepted on a free of charge basis. In some countries you may be able to return your products to your local retailer upon the purchase of a new product. Disposing of this product correctly will help you save valuable resources and prevent any possible effects on human health and the environment, which could otherwise arise from inappropriate waste handling. Please contact your local authority for further details of your nearest collection point for WEEE.